



User Guide

Wireless Analogue Signal Sensor

Applies to: ZVO-20, ZVO-22

EPI-206-00

© EpiSensor

Table of Contents

Safety Information	4
Electrical Installation	4
Intended Use	6
Related Documents	6
Introduction	6
Digital Signal Installation	6
Configuring the Jumpers	7
Input Operation	8
Dry Signal	8
Open Collector Signal	8
Active Signal	9
User Interface	9
Status LED	10
Alt LED	10
Mode Button	11
Install Mode	11
Electrical Installation	12
Mechanical	12
Enclosure & Label Material	12
Mounting Instructions	12
Opening the Enclosure	13
Tamper Evident Seals	13
Compliance	14
Wireless Communications	15
Sensors	16
Ordering Information	17
Troubleshooting & Support	17

Warranty



17

Glossary

17

Safety Information

Please read these instructions carefully before trying to install, operate, service or maintain the ZVO. The following special notes may appear throughout the user guide (or on the equipment labels) to warn of potential hazards or to call attention to information that clarifies or simplifies a procedure for users.



Symbol	Description
	The addition of either symbol to a “Danger” or “Warning” safety label indicates that an electrical hazard exists which will result in personal injury if the instructions are not followed.
	This is the safety alert symbol. It is used to alert you to potential personal injury hazards. Obey all safety messages that follow this symbol to avoid possible injury or death.

Electrical Installation

Electrical equipment should be installed, operated, serviced and maintained only by qualified personnel. No responsibility is assumed by EpiSensor for any consequences arising out of the use of this material.

A qualified person is one who has skills and knowledge related to the construction, installation, and operation of electrical equipment and has received safety training to recognize and avoid the hazards involved.

Installation, wiring, testing and service must be performed in accordance with all local and national electrical codes.

	HAZARD OF ELECTRIC SHOCK, EXPLOSION, OR ARC FLASH	
→	NEVER work alone.	
→	Use appropriate personal protective equipment (PPE) and follow safe electrical work practices.	
→	Only qualified electrical workers should install this equipment. Such work should be performed only after reading the entire set of installation instructions.	
→	If the equipment is not used in a manner specified by EpiSensor, the protection provided by the equipment may be impaired.	

- Before performing visual inspections, tests, or maintenance on this equipment, disconnect all sources of electric power. Assume that all circuits are live until they have been completely de-energized, tested, and tagged. Pay particular attention to the design of the power system. Consider all sources of power, including the possibility of backfeeding.
- Turn off all power supplying the ZVO and the area in which it is installed before working on it.
- Always use a properly rated voltage sensing device to confirm that all power is off.
- Before closing all covers and doors, inspect the work area for tools and objects that may have been left inside the equipment or panel.
- When removing or installing metering or other equipment, do not allow it to extend into an energised bus.
- The successful operation of this equipment depends upon proper handling,
- Neglecting fundamental installation requirements may lead to personal injury as well as damage to electrical equipment or other property.
- Before performing Dielectric (Hi-Pot) or Megger testing on any equipment in which the energy meter is installed, disconnect all input and output wires to the ZVO.
- High voltage testing may damage electronic components contained in the ZVO.
- Failure to follow these instructions will result in death or serious injury.

Installation & Safety Notes

- EpiSensor equipment should be installed, operated, serviced and maintained only by qualified personnel. EpiSensor does not assume any responsibility for any consequences arising out of the use of this equipment.
- Fuse for neutral terminal is required if the source neutral connection is not grounded.
- Clearly label the device's disconnect circuit mechanism and install it within easy reach of the operator.
- The fuses / circuit breakers must be rated for the installation voltage and sized for the available fault current.

Intended Use

Do not use this device for critical control or protection applications where human or equipment safety relies on the operation of the control circuit. Failure to follow these instructions can result in death, serious injury, or equipment damage.

Related Documents

Related installation and configuration documents are listed in the following table:

Document	Reference No.
EpiSensor ZVO-2x Datasheet	EPI-XXX-xx
Install Sheet for ZVO-2X	EPI-089-00
Gateway API User Guide	ESE-009-08

Introduction

EpiSensor’s ZVO 0-10 Volt Sensor is intended to detect the voltage across a pair of wires from a 0-10 Volt transducer. These transducers can measure a variety of real world conditions such as wind speed or direction, weights, volumes and depths. The ZVO reports the data through the wireless sensor network to the Gateway.

The ZVO reports data in terms of the measured voltage signal. This value needs to be converted externally since the parameter being measured is not known to the ZVO. This allows a single product to become quite versatile and measure a variety of different transducers for different properties. The ZVO-20/22 product variants are both mains powered versions. The available product variants are as follows:

SKU	Description
ZVO-20	Single channel, mains powered 0-10 Volt sensor
ZVO-22	Dual channel, mains powered 0-10 Volt sensor

4-20 Milliamp Installation

The 0-10 Volt signal wires should be fed through the enclosure’s M10 waterproof glands and connected to the terminal block, as shown in the diagram below, taking note of the positive and negative terminals. There will be 2 terminals used per channel, so the dual-channel version (ZVO-22) would use 4 terminals. The input wires are connected to IN1 for single channel models, and IN1 and IN2 for dual-channel models.

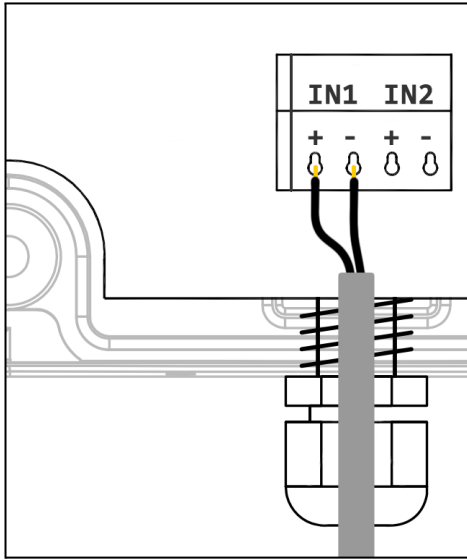

Diagram of a digital signal connected to Input 1 of the single-channel ZVO-20

Note: the single-channel version may use the same hardware as the dual channel version and so would also have a 4-pin terminal block. However, only the first channel (IN1) will be enabled on the ZVO-20 variant.

The voltage across the terminals is polarity sensitive so it should be connected positive to positive (+) and negative (or ground) to negative (-) terminal. The ZVO is polarity sensitive. Do not install the signal wires in reverse.

Configuring the Jumpers

To the right of the terminal block there is a selector grid that is used to enable various parts of the circuit for different applications. There are two rows of jumpers in the grid, the top row for IN1 and the bottom for IN2. The columns of the grid are used to configure the input type. The options are:

- AP for Active Signal or Pulse Inputs (not used on the ZVO product range)
- DP for Dry Signal or Pulse Inputs, or Open Collector Inputs (not used on the ZVO product range)
- 0-10 for 0-10 Volt Sensors - The jumper must be placed on this selector for the ZVO.
- 4-20 for 4-20 Milliamp Sensors (not used on the ZVO product range)

The image below shows a dual channel mains powered digital signal sensor where IN1 is incorrectly configured for a Dry Signal/Pulse and IN2 is correctly configured for a 0-10 Volt input:

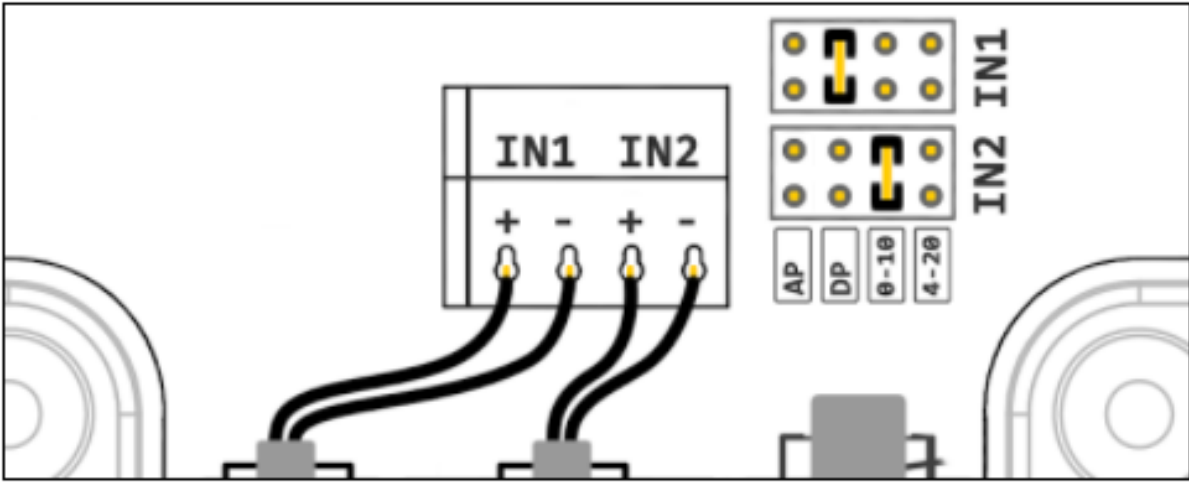
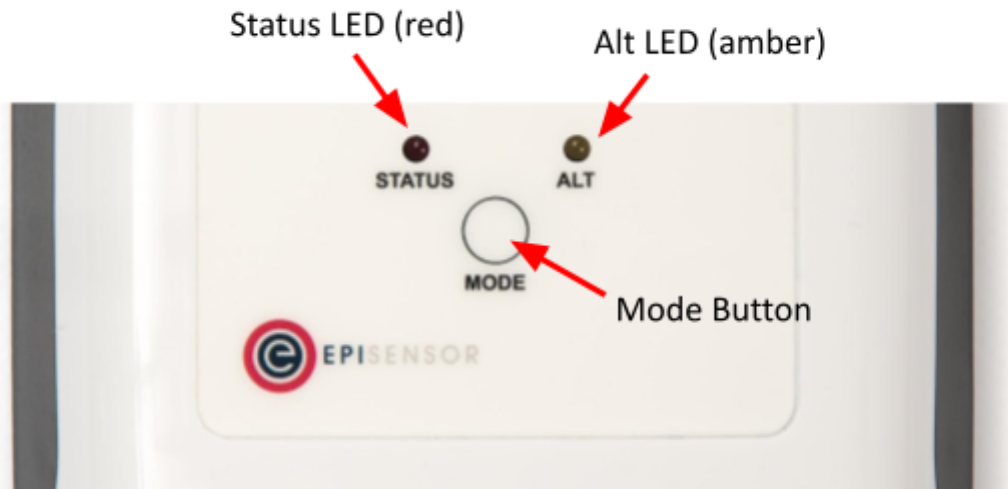

Diagram showing ZVO-22 with IN1 incorrectly configured for an Dry Pulse, and IN2 correctly configured for a 0-10 Volt input

User Interface

There are two LED's and one button on the front panel of the ZVO product range that are used to show the status of the product and to issue commands. This section describes how to interact with user interface and what each state means.



A node must be in “command mode” before users can interact with the product. To put the node in Command Mode, press and hold the “MODE” button for 2 seconds, then release. At this point, a battery powered node will switch the LED On Solid, while a mains powered node will flicker the LED and then switch the LED On Solid.

Status LED

The red status LED will flash in different sequences depending on the current state of the ZVO. This table below lists all possible LED flash sequences and their meaning.

Flash Sequence	Description	Diagram
Heartbeat	The node is operating correctly and has successfully joined a wireless network.	
Inverse Heartbeat	The node has valid security keys, but is not connected to a Gateway.	
Square Wave	The node is operating correctly but has lost contact with the Gateway.	
On Solid, or Off	If the LED is On Solid, the node does not have valid security keys and is searching for a special commissioning Gateway to join. If it is Off, the node may not be powered, or there is a problem with the node. Check the power supply, and if the problem persists, contact EpiSensor support.	

Alt LED

The Alt LED will flash when data is transmitted or received on the ZigBee wireless network. For mains powered nodes, it will always be active - but for battery powered nodes, it will only be active when in Command Mode.

Mode Button

The following options are available with Command Mode. The button should be pressed and then released to register a valid button press. If no further button presses are made, the device will terminate “command mode” 4 seconds after the last button press.

Press	Description
0	Send a PING message disable any active Install Mode or Range Test Mode. If the node is not joined, try and join a network.
1	Send a DATA message to the Gateway for any enabled sensors that are not reporting in ‘snap-to-clock’ mode.
2	Leave the current network. Mains powered Nodes will automatically try and join a new network once they have left and will periodically retry the join. Battery powered nodes will go to sleep.
4	Start “Install Mode”. Node sends a PING message every 15 seconds, with the LED pulse speed indicating the wireless signal strength of the reply. Automatically expires after 5 minutes.
6	Reboot the node. Security keys for the wireless network the node is joined to will not be erased, and all other settings will remain the same.
8	Factory-reset the node and perform a reboot. All settings and security keys will be lost. The node will be returned to its factory default state.
12	Start “Range Test” mode. Node will send a PING message every 5 seconds. The LED pulse speed indicates the wireless signal strength of the reply. Automatically expires after 5 minutes.

Install Mode

Issuing a press sequence on the Mode button of a powered node can enable either “Install Mode” or “Site Survey Mode” on that node. In this mode, the LED will flash at a rate that indicates the wireless signal strength (Link Quality Indicator) of that node, based on the following table:

Flash Rate	Flashes per Second	Wireless Signal Strength	LQI
Very Fast	10 flashes / second (Light on 50ms, off 50ms)	Very good Signal	> 200
Fast	2 flashes / second (LED on 250ms, off 250ms)	Good Signal	> 150
Slow	1 flash / 2 seconds (LED on 1 sec, off 1 sec)	OK Signal	> 100
Very Slow	1 flash / 6 seconds (LED on 3 sec, off 3 sec)	Poor Signal	< 100

This mode expires after 15 minutes for Install Mode and 5 minutes for Site Survey Mode.

Electrical Installation

The ZVO-20/22 is a mains powered device – the mains cable is colour coded to conform to European CENELEC standards. The CENELEC standard insulation colours are as follows:

Live – **Brown**

N – **Blue**

Important Note: The ZVO-20/22 should be connected via a switched junction box and breaker to protect the cable. Also, please ensure that the live connection is made on the same circuit as the neutral connection where residual-current devices (RCD's) are used.

Installation should only be carried out only by personnel qualified in the installation of electrical equipment. All parts of the circuit within the enclosure must be considered to be at dangerously high mains voltage when the unit is connected to a mains voltage source.

Mechanical

This section describes how to wall-mount the ZVO enclosure, the enclosure materials and important safety considerations when connecting the ZVO to external systems.

Enclosure & Label Material

The ZVO is housed in an IP67 water and dust proof enclosure to provide maximum safety, flexibility and reliability. The enclosure material is polycarbonate plastic, which is resistant to a variety of chemicals, oils and detergents.

The front label is made from polycarbonate. There will be two or more labels on the back of the enclosure, depending on the model selected. The compliance label is made from PVC and the serial number label is made from polyethylene film.

Mounting Instructions

The ZVO-20/22 product range will have two or three cable glands at the bottom for the digital signal inputs depending on the model.

The ZVO product requires 2 screws for mounting. These screws can be preinstalled on a vertical surface spaced 122mm vertically apart. The head of the screw should be less than 8.5mm in diameter and the screw thickness should be less than 4.5mm. The screws should be left unscrewed by more than 5 mm before installing the enclosure.

Important Safety Note



The enclosure of the ZVO must not be drilled, cut or modified in any way for mounting or connecting to external systems.

All parts of the circuit within the enclosure must be considered to be at dangerously high mains voltage when the unit is connected to a mains voltage source. Modifying the enclosure could expose parts of the system to users, or cause an internal fault or short circuit.

There are no user-serviceable parts inside the ZVO enclosure, and it should always be isolated from mains voltages before opening the enclosure lid.

Opening the Enclosure

To make connections to the ZVO, it is necessary to open the lid of the enclosure. This is fastened with four screws that are accessible from the back of the enclosure. This should only be done by qualified personnel, and only when the ZVO has been isolated from any high voltage supplies. Please consult the safety notes at the start of this user guide for more information.

Important Safety Note



EpiSensor equipment should be installed, operated, serviced and maintained only by qualified personnel.

There are no user-serviceable parts inside the ZVO enclosure, and it should always be isolated from mains voltages before opening the enclosure lid.

When closing the lid, take care to ensure that no wires or cable ties are obstructing the gasket of the enclosure, as this could interfere with the waterproof seal. When tightening the screws on the lid, apply pressure to the enclosure so the gasket is compressed, and tighten each screw gradually and in sequence.

Tamper Evident Seals



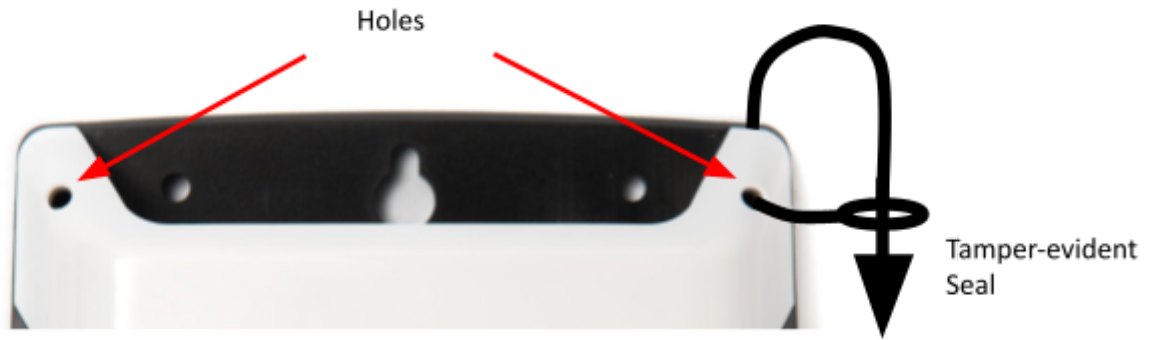



Some applications (particularly applications where data is used for billing purposes) will require a tamper evident seals to be attached to the ZVO enclosure. These seals can be attached to two or more of the corners of the ZVO enclosure, as shown on the diagram below.



Compliance

There is a compliance label on the back of the ZVO enclosure that has important regulatory and node identification information.

The label material is gloss white PVC foil with permanent adhesive and gloss overlaminate. The following table lists the certification and safety symbols that appear on the certification labels of EpiSensor products. Please refer to it for a definition of each symbol.

Symbol	Name	Description
	CE Mark	This marking certifies that a product has met EU consumer safety, health or environmental requirements.
	WEEE Symbol	The directive imposes the responsibility for the disposal of waste electrical and electronic equipment on the manufacturers of such equipment.
	Class II IEC Protection	This certifies that this product has been designed in such a way that it does not require a safety connection to electrical earth/ground.
	IP / NEMA Rating	Water and dust ingress protection standard. IP67 / NEMA 4 means complete protection against contact with dust, and protected from ingress of water when immersed in up to 1 metre depth for up to 30 minutes. For more information, see IEC 60529.
	RoHS Directive	Restriction of Hazardous Substances Directive restricts (with exceptions) the use of six hazardous materials in the manufacture of various types of electronic and electrical equipment.
	Safety Alert	This is the safety alert symbol. It is used to alert you to potential personal injury hazards. Obey all safety messages that follow this symbol to avoid possible injury or death.



Danger / Warning

The addition of either symbol to a “Danger” or “Warning” safety label indicates that an electrical hazard exists which will result in personal injury if the instructions are not followed.

EpiSensor products are not suitable or specifically designed, manufactured or licensed for use in military, aviation, powerplant, medical or in other inherently dangerous or safety critical applications.

Wireless Communications

All EpiSensor products use IEEE 802.15.4 ZigBee Pro for wireless communications operating at 2.4GHz. This is a secure, scalable mesh networking communications protocol designed for transmitting small amounts of data reliably, and at low power levels.

There are two types of nodes in the EpiSensor wireless mesh network: powered nodes and battery nodes. Powered nodes on the wireless sensor network are capable of routing data from any other type of wireless nodes.

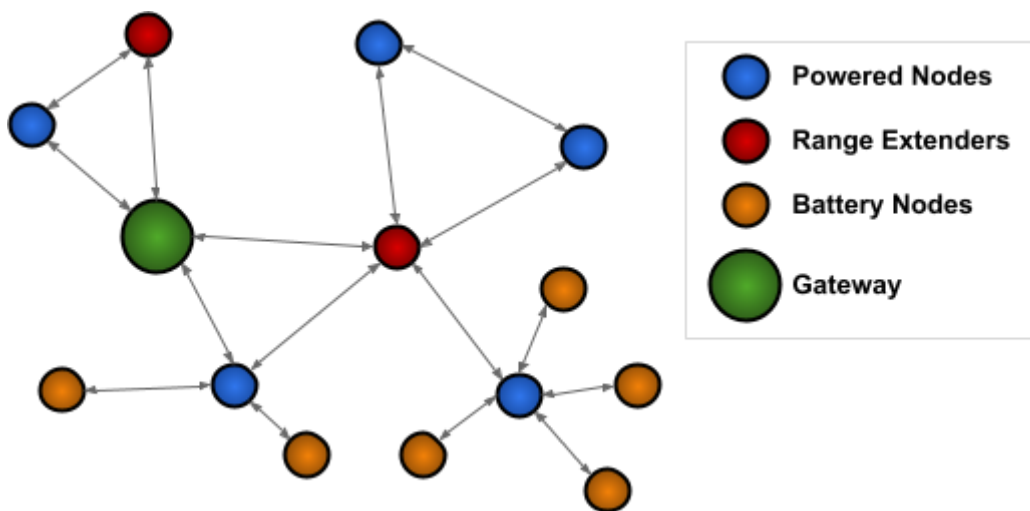

Range extenders are powered nodes where the main function is to route data. Any node with a mains power supply will act as a routing node in the network. Battery nodes do not route data – they spend most of the time in a low power mode.

Each powered node can have up to 32 ‘neighbours’ which are nodes with a mains power supply and can Route data back to the Gateway. They can also have up to 32 ‘children’ which are nodes that are battery powered and cannot participate in any routing in the network.

The range that can be achieved with ZigBee will depend mainly on two factors: the power level of the ZigBee radio module and the environment that the device is installed in. There are two types of ZigBee radio module used across the EpiSensor product range, a power amplified version, and non-power amplified version.

The power output of nodes with a power-amplified module can be configured with an output power level of +20 dBm depending on the region they are deployed in. Non-power amplified nodes have a maximum output power of +8 dBm.

Module Type	Tx Power	Rx Sensitivity	LoS Range	Region(s)
Normal	+8 dBm	-101dBm	up to 300m (985ft)	Worldwide
Power-amplified	+20 dBm	-106dBm	up to 1600m (5250ft)	North America (FCC / IC)

All communications over the ZigBee wireless network is AES 128-bit encrypted. For more detailed information on ZigBee security features, contact EpiSensor support.

Sensors

The following is a list of all sensors available on the ZVO. The reporting mode, reporting interval and logging enabled columns refer to the factory default settings, these settings can be configured from the Gateway.

Sensor ID	Name	Description	Reporting Mode	Reporting Interval	Logging Enabled
390	4-20 Volts Now 1	The instantaneous value of the 0-10 Volt signal on the IN1 input	Snap to Clock	15	Yes
391	4-20 Volts Avg 1	The average value on the 0-10 Volt signal since the last reported value on the IN1 input for this sensor ID 391.	Off	15	Yes
392	4-20 Volts Min 1	The minimum value on the 0-10 Volt signal since the last reported value on the IN1 input for this sensor ID 392.	Off	15	Yes
393	4-20 Volts Max 1	The maximum value on the 0-10 Volt signal since the last reported value on the IN1 input for this sensor ID 393.	Off	15	Yes
490	4-20 Volts Now 2	The instantaneous value of the 0-10 Volt signal on the IN2 input	Snap to Clock	15	Yes
491	4-20 Volts Avg 2	The average value on the 0-10 Volt signal since the last reported value on the IN2 input for this sensor ID 491.	Off	15	Yes
492	4-20 Volts Min 2	The minimum value on the 0-10 Volt signal since the last reported value on the IN2 input for this sensor ID 492.	Off	15	Yes

493	4-20 Volts Max 2	The maximum value on the 0-10 Volt signal since the last reported value on the IN2 input for this sensor ID 493.	Off	15	Yes
-----	------------------	--	-----	----	-----

Ordering Information

EpiSensor products are available to order directly or via EpiSensor’s distribution partners. The following table lists the available ZVO options.

SKU	Description
ZVO-20	Single channel, mains powered 0-10 Volt sensor
ZVO-22	Dual channel, mains powered 0-10 Volt sensor

Troubleshooting & Support

If you are experiencing problems with your ZVO or any other part of your EpiSensor system, or you notice something unusual - please contact EpiSensor support at the following email address, phone number or via live chat on our website.

- Email: support@episensor.com
- Tel: +353 61 512 500
- Website: <http://episensor.com>

For customers and partners who are deploying systems in business-critical environments, there are a number of support packages available that offer a higher level of service and response time. For more information on EpiSensor Premium Support, visit: <http://episensor.com/premium-support/>

Warranty

All EpiSensor products and provided with a 365 day limited warranty effective from the shipping/invoice date of an order. During the warranty period, under the conditions of normal use, EpiSensor will repair or replace any product that has a manufacturing defect.

Warranty can be extended by up to 4 years within 30 days of a purchase. For more information on warranty, visit: <http://episensor.com/warranty/>

Glossary

Definitions for terms and abbreviations used in this document are listed in the following table:

Term	Description
Sensor	Describes a feed of data within the EpiSensor system
Node	Used to describe a physical EpiSensor product
Gateway	The central computer that managed the EpiSensor system
ZigBee	IEEE 802.15.4 Wireless communications standard that EpiSensor nodes use
WSN	Wireless Sensor Network
Reporting Mode	Defines how an EpiSensor node should report data to the Gateway
Reporting Interval	The length of time between each data point produced by a node
Snap to Clock	Reporting mode where data is 'snapped' to the nearest 1 minute / 5 minute / 15 minute interval etc.
Interval and Delta	Reporting mode where data is produced when the reporting interval has elapsed, unless a change is detected
Allow join mode	A mode that can be enabled on the Gateway that allows new wireless nodes to join